

REPLACEMENT PARTS SUITABLE FOR BYSTRONIC®

PARTS FOR BYSTRONIC® "BY" SERIES

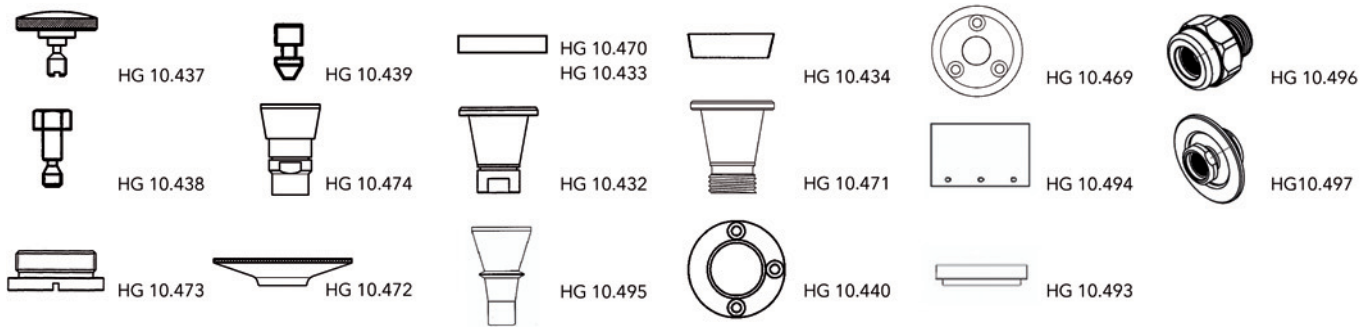

Part No.	Ref. No.	Description	Std. Pkg.	Part No.	Ref. No.	Description	Std. Pkg.
HG10.437	4-03136	Knurled screw	1pc	HG10.470	4-09010	Ceramic	1pc
HG10.438	4-00324	Knurled screw	1pc	HG10.472	2-08700	Shield (copper)	1pc
HG10.439	4-03137	Pln	1pc	HG10.493	3-13113	Insulating ring (small)	1pc
HG10.474	3-02291	Nozzle body	1pc	HG10.495	2-10837	Nozzle body	1pc
HG10.433	4-01642	Insulating ring - ceramic	1pc	HG10.494	3-13422	Insulating ring (large)	1pc
HG10.432	3-05497	Nozzle body	1pc	HG10.440	3-06035	Insulating disc (PTFE)	1pc
HG10.434	4-01959	Conical ceramic	1pc	HG10.469	3-03663	Insulating disc (PTFE) - old.ref.	1pc
HG10.471	2-08701	Nozzle body	1pc	HG10.496	10055576	Nozzle holder BySprint	1pc
HG10.473	3-11071	Fastener nut	1pc	HG10.497	10051133	Nozzle holder BySprint	1pc

PARTS FOR BYSTRONIC® "BY" SERIES



HG 10.403-405



HG 10.408-412



HG 10.413-417

Part No.	Ref. No.	Description	Std. Pkg.	Part No.	Ref. No.	Description	Std. Pkg.
HG10.403	3-01894	Nozzle 1,0mm - 10	10pcs	HG10.410/C	3-01901CP	Nozzle 1,50mm - H15 - HCP	10pcs
HG10.403/C	3-01894CP	Nozzle 1,0mm - 10 - HCP	10pcs	HG10.411	3-01902	Nozzle 1,75mm - H17	10pcs
HG10.404	3-01895	Nozzle 1,25mm - 12	10pcs	HG10.411/C	3-01902CP	Nozzle 1,75mm - H17 - HCP	10pcs
HG10.404/C	3-01895CP	Nozzle 1,25mm - 12 - HCP	10pcs	HG10.412	3-01903	Nozzle 2,0mm - H20	10pcs
HG10.405	3-01896	Nozzle 1,50mm - 15	10pcs	HG10.412/C	3-01903CP	Nozzle 2,0mm - H20 - HCP	10pcs
HG10.405/C	3-01896CP	Nozzle 1,50mm - 15 - HCP	10pcs	HG10.413	3-01905	Nozzle 1,0mm - K10	10pcs
HG10.408	3-01899	Nozzle 1,00mm - H10	10pcs	HG10.413/C	3-01905CP	Nozzle 1,0mm - K10 - HCP	10pcs
HG10.408/C	3-01899CP	Nozzle 1,00mm - H10 - HCP	10pcs	HG10.414	3-01906	Nozzle 1,25mm - K10	10pcs
HG10.409	3-01900	Nozzle 1,25mm - H12	10pcs	HG10.414/C	3-01906CP	Nozzle 1,25mm - K10 - HCP	10pcs
HG10.409/C	3-01900CP	Nozzle 1,25mm - H12 - HCP	10pcs	HG10.415	3-01907	Nozzle 1,50mm - K15	10pcs
HG10.410	3-01901	Nozzle 1,50mm - H15	10pcs	HG10.415/C	3-01907CP	Nozzle 1,50mm - K15 - HCP	10pcs

PolyTetraFluoroEthylene is a fluorocarbon-based polymer and is commonly abbreviated PTFE. The Teflon® brand of PTFE is manufactured only by DuPont and is not sold by Thermacut. Thermacut purchases other brands of PTFE from various high quality manufacturers.

BYSTRONIC® is the Registered Trademark of BYSTRONIC LASER AG.

Last update of this page: 27/06/2014. See Revision history for details.

THERMACUT®
THE CUTTING COMPANY

WWW.THERMACUT.CZ
TEL.: +420.556.423.418
SALES@THERMACUT.CZ

WWW.THERMACUT.DE
TEL.: +49 (0) 27 39 40 33 0
INFO@THERMACUT.DE

WWW.THERMACUT.COM
TEL.: 1-603-542-6715
CUSTOMERSERVICE@THERMACUT.COM

THERMACUT IS IN NO WAY AFFILIATED WITH THE ABOVE-NAMED MANUFACTURERS. REFERENCES TO THE ABOVE-NAMED MACHINES, TORCHES, CONSUMABLES AND REFERENCE NUMBERS ARE FOR CONVENIENCE ONLY. MOST THERMACUT PARTS ARE MADE FOR OR BY AN IBG COMPANY. PARTS INDICATED WITH A * ARE ORIGINAL PARTS MANUFACTURED BY THE ABOVE NAMED MANUFACTURER AND ARE BEING RESOLD BY THERMACUT. THERMACUT RESERVES THE RIGHT TO SUBSTITUTE OEM PARTS IN PLACE OF THERMACUT PARTS. VALID FROM MAY 2015 • PREVIOUS VERSION IS NO LONGER VALID. • © COPYRIGHT 2015 BY THERMACUT® CZECH REPUBLIC. ALL RIGHTS RESERVED.

REPLACEMENT PARTS SUITABLE FOR BYSTRONIC®

PARTS FOR BYSTRONIC® "BY" SERIES



HG 10.414-424

Standard copper nozzles / Standard copper nozzles with hard chromium plating

Part No.	Ref. No.	Description	Std. Pkg.	Part No.	Ref. No.	Description	Std. Pkg.
HG10.416	3-01908	Nozzle 1,75mm- K17	10pcs	HG10.420/C	3-01912CP	Nozzle 1,50mm- HK 15 - HCP	10pcs
HG10.416/C	3-01908CP	Nozzle 1,75mm- K17 - HCP	10pcs	HG10.421	3-01913	Nozzle 1,75mm- HK17	10pcs
HG10.417	3-01909	Nozzle 2,00mm- K20	10pcs	HG10.421/C	3-01913CP	Nozzle 1,75mm- HK17 - HCP	10pcs
HG10.417/C	3-01909CP	Nozzle 2,00mm- K20 - HCP	10pcs	HG10.422	3-01914	Nozzle 2,0mm- HK20	10pcs
HG10.426	3-04274	Nozzle 2,25mm- K25	10pcs	HG10.422/C	3-01914CP	Nozzle 2,0mm- HK20 - HCP	10pcs
HG10.426/C	3-04274CP	Nozzle 2,25mm- K25 - HCP	10pcs	HG10.423	3-03854	Nozzle 2,5mm- HK25	10pcs
HG10.418	3-01910	Nozzle 1,00mm- HK10	10pcs	HG10.423/C	3-03854CP	Nozzle 2,5mm- HK25 - HCP	10pcs
HG10.418/C	3-01910CP	Nozzle 1,00mm- HK10 - HCP	10pcs	HG10.425	3-06112	Nozzle 3,0mm- HK30	10pcs
HG10.419	3-01911	Nozzle 1,25mm- HK 12	10pcs	HG10.425/C	3-06112CP	Nozzle 3,0mm- HK30 - HCP	10pcs
HG10.419/C	3-01911CP	Nozzle 1,25mm- HK 12 - HCP	10pcs	HG10.424	HG10.424	Nozzle 3,50mm- HK35	10pcs
HG10.420	3-01912	Nozzle 1,50mm- HK 15	10pcs	HG10.424/C	HG10.424CP	Nozzle 3,50mm- HK35 - HCP	10pcs



HG 10.428/D-434/D



HG 10.418/D-424/D

Standard double copper nozzles / Standard double copper nozzles with hard chromium plating

Part No.	Ref. No.	Description	Std. Pkg.	Part No.	Ref. No.	Description	Std. Pkg.
HG10.428/D	3-16058	Nozzle 1,00mm- NK10	10pcs	HG10.418/D	3-16058CP	Nozzle 1,00mm- NK10 - HCP	10pcs
HG10.429/D	3-16059	Nozzle 1,20mm- NK12	10pcs	HG10.419/D	3-16059CP	Nozzle 1,20mm- NK12 - HCP	10pcs
HG10.430/D	3-16060	Nozzle 1,50mm- NK15	10pcs	HG10.420/D	3-16060CP	Nozzle 1,50mm- NK15 - HCP	10pcs
HG10.431/D	3-14317	Nozzle 1,70mm- NK17	10pcs	HG10.421/D	3-14317CP	Nozzle 1,70mm- NK17 - HCP	10pcs
HG10.432/D	3-14318	Nozzle 2,00mm- NK20	10pcs	HG10.422/D	3-14318CP	Nozzle 2,00mm- NK20 - HCP	10pcs
HG10.433/D	3-14319	Nozzle 2,50mm- NK25	10pcs	HG10.423/D	3-14319CP	Nozzle 2,50mm- NK25 - HCP	10pcs
HG10.433/A	3-16256	Nozzle 2,50mm- NK25 - AL	10pcs	HG10.423/A	3-16256CP	Nozzle 2,50mm- NK25 - AL - HCP	10pcs
HG10.435/D	3-16061	Nozzle 3,00mm- NK30	10pcs	HG10.425/D	3-16061CP	Nozzle 3,00mm- NK30 - HCP	10pcs
HG10.435/A	3-16257	Nozzle 3,00mm- NK30 - AL	10pcs	HG10.425/A	3-16257CP	Nozzle 3,00mm- NK30 - AL - HCP	10pcs
HG10.434/D	HG10.434/D	Nozzle 3,50mm- NK35	10pcs	HG10.424/D	HG10.434DCP	Nozzle 3,50mm- NK35 - HCP	10pcs

BYSTRONIC® is the Registered Trademark of BYSTRONIC LASER AG.

Last update of this page: 19/05/2014. See Revision history for details.

THERMACUT®
THE CUTTING COMPANY

WWW.THERMACUT.CZ
TEL.: +420 556 423 418
SALES@THERMACUT.CZ

WWW.THERMACUT.DE
TEL.: +49 (0) 27 39 40 33 0
INFO@THERMACUT.DE

WWW.THERMACUT.COM
TEL.: 1-603-542-6715
CUSTOMERSERVICE@THERMACUT.COM

THERMACUT IS IN NO WAY AFFILIATED WITH THE ABOVE-NAMED MANUFACTURERS. REFERENCES TO THE ABOVE-NAMED MACHINES, TORCHES, CONSUMABLES AND REFERENCE NUMBERS ARE FOR CONVENIENCE ONLY. MOST THERMACUT PARTS ARE MADE FOR OR BY AN IBG COMPANY. PARTS INDICATED WITH A * ARE ORIGINAL PARTS MANUFACTURED BY THE ABOVE NAMED MANUFACTURER AND ARE BEING RESOLD BY THERMACUT. THERMACUT RESERVES THE RIGHT TO SUBSTITUTE OEM PARTS IN PLACE OF THERMACUT PARTS. VALID FROM MAY 2015 • PREVIOUS VERSION IS NO LONGER VALID. • © COPYRIGHT 2015 BY THERMACUT® CZECH REPUBLIC. ALL RIGHTS RESERVED.

REPLACEMENT PARTS SUITABLE FOR BYSTRONIC®

LENSES SUITABLE FOR BYSTRONIC®

Part No.	Ref. No.	Description	Std. Pkg.
HG10.730/H	4-00185	3,75" ZnSe Meniscus lens High pressure lens (20bar), 38,1mm Effective focal length: 95,3mm Edge thickness: 6,0 mm AR/AR for 10,6um (absorption <0.20%)	1pc
HG10.731/H	4-00186	5,00" ZnSe Meniscus lens High pressure lens (20bar), 38,1mm Effective focal length: 127,0mm Edge thickness: 6,0 mm AR/AR for 10,6um (absorption <0.20%)	1pc
HG10.732/H	4-00187	7,50" ZnSe Meniscus lens High pressure lens (20bar), 38,1mm Effective focal length: 190,5mm Edge thickness: 6,0 mm AR/AR for 10,6um (absorption <0.20%)	1pc
HG10.729/H	4-10736	3,75" ZnSe Meniscus lens High pressure lens (42bar), 38,1mm Effective focal length: 95,3mm Edge thickness: 9,0mm AR/AR for 10,6um (absorption <0.20%)	1pc

Part No.	Ref. No.	Description	Std. Pkg.
HG10.733/H	4-05094	5,00" ZnSe Meniscus lens High pressure lens (42bar), 38,1mm Effective focal length: 127,0mm Edge thickness: 9,0mm AR/AR for 10,6um (absorption <0.20%)	1pc
HG10.734/H	4-05095	7,50" ZnSe Meniscus lens High pressure lens (42bar), 38,1mm Effective focal length: 190,5mm Edge thickness: 9,0mm AR/AR for 10,6um (absorption <0.20%)	1pc
HG10.733/HU	4-07475	5,00" ZnSe Meniscus lens - ULTRA LOW High pressure lens (42bar), 38,1mm Effective focal length: 127,0mm Edge thickness: 9,0mm AR/AR for 10,6um (absorption <0.15%)	1pc
HG10.734/HU	4-07476	7,50" ZnSe Meniscus lens - ULTRA LOW High pressure lens (42bar), 38,1mm Effective focal length: 190,5mm Edge thickness: 9,0mm AR/AR for 10,6um (absorption <0.15%)	1pc

ACCESSORIES SUITABLE FOR BYSTRONIC®

Part No.	Ref. No.	Description	Std. Pkg.
HG10.174	HG10.174	Polish for laser optics, 100ml	1pc
HG10.173	HG10.173	Lens cleaning paper from Tiffen, sheet size 70x115mm	50pcs
HG15.136	HG15.136	Latex gloves	100pcs
HG15.138	HG15.138	EM-080 general purpose cleaning concentrate, 500ml	1pc
HG15.099	HG15.099	Cleaning holder (PTFE) for lenses (to use on both sides), 38,1mm or 50,8mm	1pc

PolyTetraFluoroEthylene is a fluorocarbon-based polymer and is commonly abbreviated PTFE. The Teflon® brand of PTFE is manufactured only by DuPont and is not sold by Thermacut. Thermacut purchases other brands of PTFE from various high quality manufacturers.

BYSTRONIC® is the Registered Trademark of BYSTRONIC LASER AG.

Last update of this page: 19/05/2014. See Revision history for details.

THERMACUT®
THE CUTTING COMPANY

WWW.THERMACUT.CZ
TEL.: +420.556 423 418
SALES@THERMACUT.CZ

WWW.THERMACUT.DE
TEL.: +49 (0) 27 39 40 33 0
INFO@THERMACUT.DE

WWW.THERMACUT.COM
TEL.: 1-603-542-6715
CUSTOMERSERVICE@THERMACUT.COM

THERMACUT IS IN NO WAY AFFILIATED WITH THE ABOVE-NAMED MANUFACTURERS. REFERENCES TO THE ABOVE-NAMED MACHINES, TORCHES, CONSUMABLES AND REFERENCE NUMBERS ARE FOR CONVENIENCE ONLY. MOST THERMACUT PARTS ARE MADE FOR OR BY AN IBG COMPANY. PARTS INDICATED WITH A * ARE ORIGINAL PARTS MANUFACTURED BY THE ABOVE NAMED MANUFACTURER AND ARE BEING RESOLD BY THERMACUT. THERMACUT RESERVES THE RIGHT TO SUBSTITUTE OEM PARTS IN PLACE OF THERMACUT PARTS. VALID FROM MAY 2015 • PREVIOUS VERSION IS NO LONGER VALID. • © COPYRIGHT 2015 BY THERMACUT® CZECH REPUBLIC. ALL RIGHTS RESERVED.

REPLACEMENT PARTS SUITABLE FOR BYSTRONIC®

AIR FILTERS SUITABLE FOR BYSTRONIC®

Part No.	Ref. No.	Description	Std. Pkg.	Part No.	Ref. No.	Description	Std. Pkg.
HG10.175	HG10.175	Air filter for cooling aggregate size: 400 x 600 x 8mm	25pcs	HG11.179	HG11.179	Air filter for cooling aggregate size: 600 x 1200 x 8mm	25pcs
HG10.176	HG10.176	Air filter for cooling aggregate size: 800 x 600 x 8mm	25pcs	HG11.176	HG11.176	Air filter for cooling aggregate size: 1050 x 1050 x 8mm	25pcs

BYSTRONIC® is the Registered Trademark of BYSTRONIC LASER AG.

Last update of this page: 09/09/2013. See Revision history for details.

THERMACUT®
THE CUTTING COMPANY

WWW.THERMACUT.CZ
TEL.: +420.556 423 418
SALES@THERMACUT.CZ

WWW.THERMACUT.DE
TEL.: +49 (0) 27 39 40 33 0
INFO@THERMACUT.DE

WWW.THERMACUT.COM
TEL.: 1-603-542-6715
CUSTOMERSERVICE@THERMACUT.COM

THERMACUT IS IN NO WAY AFFILIATED WITH THE ABOVE-NAMED MANUFACTURERS. REFERENCES TO THE ABOVE-NAMED MACHINES, TORCHES, CONSUMABLES AND REFERENCE NUMBERS ARE FOR CONVENIENCE ONLY. MOST THERMACUT PARTS ARE MADE FOR OR BY AN IBG COMPANY. PARTS INDICATED WITH A * ARE ORIGINAL PARTS MANUFACTURED BY THE ABOVE NAMED MANUFACTURER AND ARE BEING RESOLD BY THERMACUT. THERMACUT RESERVES THE RIGHT TO SUBSTITUTE OEM PARTS IN PLACE OF THERMACUT PARTS. VALID FROM MAY 2015 • PREVIOUS VERSION IS NO LONGER VALID. • © COPYRIGHT 2015 BY THERMACUT® CZECH REPUBLIC. ALL RIGHTS RESERVED.